

REVISED

3:04 pm, Mar 28, 2007



Vision processors

Matrox Odyssey Xpro >>>

Scalable vision processor board.

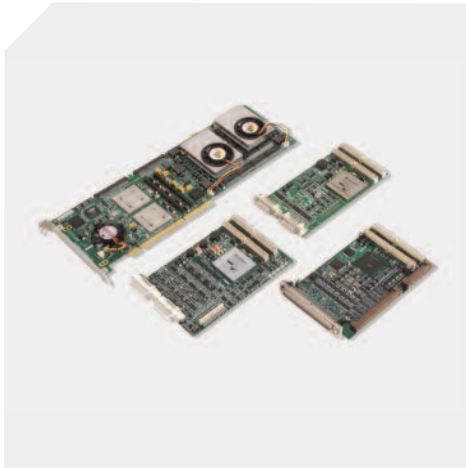

Key features

- > PCI-X long card
- > G4 PowerPC™ and proprietary ASIC combine for up to 140 BOPS¹
- > over 5 GB per second of memory bandwidth
- > up to 2 GB of DDR SDRAM memory
- > up to 2 GB per second of external I/O bandwidth
- > PMC site for optional frame grabber module
- > Camera Link® frame grabber module acquires up to 680 MB per second
- > quad-input analog frame grabber module acquires up to 800 MB per second
- > LVDS/RS-422 frame grabber module acquires up to 480 MB per second
- > pair of dedicated board-to-board interconnects each capable of up to 1 GB per second
- > available software is sold separately and includes Matrox Imaging Library (MIL)², Matrox Odyssey Native Library (ONL), Matrox Odyssey Developer's Toolkit and Matrox Inspector³
- > host OS support for Microsoft® Windows® 2000, Windows® XP and Linux³
- > royalty-free redistribution of MIL and ONL run-time environments²

Evolutionary architecture with leading-edge performance

Matrox Odyssey Xpro is a fourth generation vision processor board that combines optimal off-the-shelf and custom technologies within an established architecture to deliver leading-edge performance and value. Designed with demanding semiconductor inspection, medical imaging, print inspection, surface inspection and signal processing applications in mind, the Matrox Odyssey Xpro is the ideal choice for applications with data acquisition and processing rates in the order of hundreds of MBytes per second and/or where the PC is heavily loaded with other system activities.

The premier embedded microprocessor, state-of-the-art proprietary processor and router ASICs, DDR memory, and PCI-X® interconnectivity come together on the Matrox Odyssey Xpro to provide incredible power for a single vision processor board. Additionally, the Matrox Odyssey Xpro is ready to expand to meet today and tomorrow's processing requirements with its linearly scalable architecture. All this power and flexibility is accessed through an easy-to-learn programming environment compatible with Matrox Imaging's previous generation vision processor and incorporating elaborate image processing and analysis algorithms.

State-of-the-art Matrox Oasis ASIC

The Matrox Imaging designed Oasis ASIC is the pivotal component of the Matrox Odyssey Xpro. A high-density chip, the Matrox Oasis integrates a CPU bridge, Links Controller, main memory controller and Pixel Accelerator.



»» Matrox Odyssey Xpro

* Shared between Matrox Oasis and SIBs.

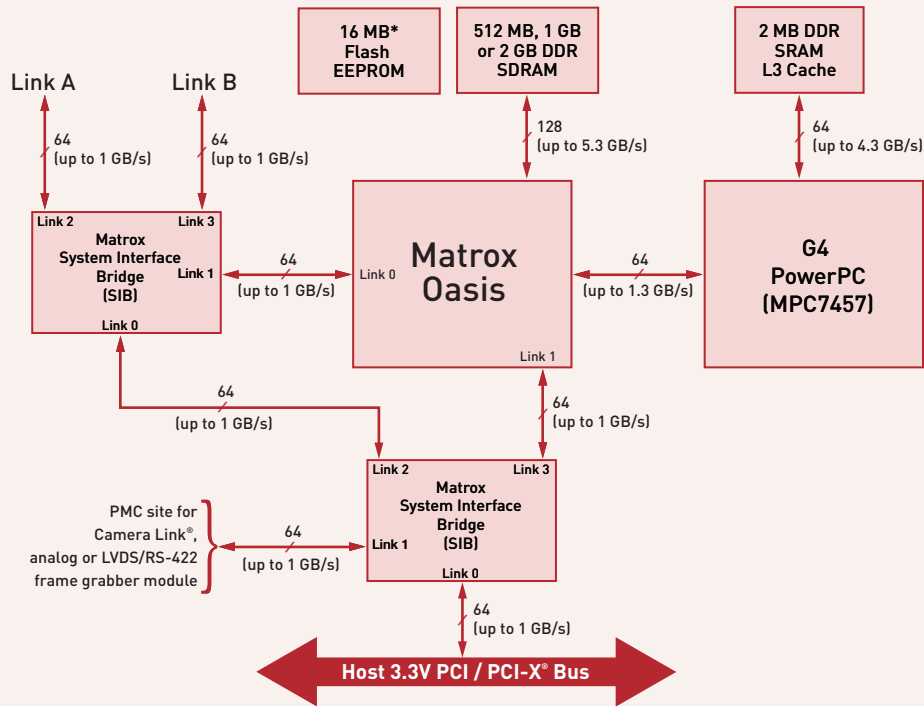

Pixel Accelerator

The Pixel Accelerator (PA) is a parallel processor core, which considerably accelerates neighborhood, point-to-point and LUT mapping operations. It consists of an array of 64 processing elements all working in parallel. Each processing element has a multiply-accumulate (MAC) unit and an arithmetic-logic unit (ALU).

The MAC unit is capable of performing a single 16-bit by 16-bit, two 8-bit by 16-bit or four 8-bit by 8-bit multiplies with 40-bit accumulation per cycle for convolution operations. The 40-bit accumulator guarantees no overflow situation for a 16 by 16 kernel with 16-bit coefficients and data. In addition, the PA architecture allows symmetrical kernels to be processed four times faster. The MAC unit is also able to perform up to four minimum or maximum operations per cycle for grayscale morphology operations.

The ALU can execute a wide variety of arithmetic and logical operations. It can be programmed to execute a sequence of 256 instructions per pixel at one instruction per cycle reducing the amount of memory accesses and further accelerating memory I/O-bound sequences. The PA can accept up to four source buffers⁴ and output to four destination buffers allowing several operations to be performed at once or in a single pass (e.g., four images can be averaged in one pass). Operating at a core frequency of 167 MHz enables the PA to carry out up to 100 BOPS¹ (i.e., process over two billion pixels per second).

Memory controller

The Matrox Oasis includes a very efficient main memory controller for managing the 128-bit wide interface to DDR SDRAM. Operating at 167 MHz, the DDR SDRAM and controller combine to deliver a memory bandwidth in excess of 5 GB per second. Such ample memory bandwidth allows the Odyssey Xpro to comfortably handle demanding video I/O while maintaining PA performance even for memory I/O-bound operations.

Links Controller

The Links Controller (LINX) is the router that manages all data movement inside and outside the processing node, which consists of the PA, CPU and main memory. It can handle several concurrent video and message streams.

Video streams are used to transfer image data from one or more frame grabber modules to one or more processing nodes, between processing nodes, and from one or more processing nodes to the host PC and display. The video streams have adjustable priority levels, either above or below message streams. Video streams can be subject to various formatting operations including plane separation on input and merging on output, input cropping, input and output sub-sampling (1 to 16), and independent control of horizontal and vertical scanning direction. The latter is particularly useful for reconstructing a proper image from a camera whose readout requires multiple taps, each with different scanning directions.

Links Controller (cont.)

Message streams are for all types of inter-processor communications. The LINX handles message streams between a processing node and the host PC or other processing nodes independently of video streams. Message passing relies on hardware-assisted mechanisms for low overheads and real-time operation. Together, the above capabilities off-load the CPU and PA from data management tasks so they can focus on image processing tasks.

freemove™ G4 PowerPC™ microprocessor

The CPU that controls activities on the Matrox Odyssey Xpro and performs operations not supported by the PA is the *freemove™ G4 PowerPC™* microprocessor. The G4 combines the best features of a general purpose CPU and a DSP, and provides top performance at a given clock rate. The G4 is also backed by *freemove™*'s solid migration path for increased performance, all the while maintaining code compatibility.

The G4 incorporates a powerful 32-bit superscalar RISC and AltiVec™ technology's 128-bit vector execution unit. 512 KB of internal L2 cache and 2 MB external L3 cache help sustain maximum processor performance. A 64-bit MPX bus offers efficient access to main memory and provides a sustained bandwidth close to its theoretical maximum of 1.3 GB per second.

AltiVec™ technology is specifically designed to meet the heavy computational requirements of applications such as video and image processing. This technology consists of a high-performance parallel processing engine for vector data. It uses the SIMD (single instruction, multiple data) model to process, in parallel, up to 16 pixels per cycle. It delivers a peak processing power of 20 billion 8-bit MACs per second or 10 billion 32-bit floating point operations per second when running at 1.3 GHz. Additionally, AltiVec™ technology operates concurrently with other execution units within the G4.

Lightning fast connectivity

PCI-X® is the fabric used on the Matrox Odyssey Xpro to connect a processing node to other processing nodes and PMC devices including an optional frame grabber module. It also connects the Matrox Odyssey Xpro to the host PC and display. PCI-X® is a high-performance backwards-compatible enhancement to the conventional PCI bus specification. Version 1.0 of PCI-X® specifies a 64-bit physical connection running at speeds of up to 133MHz resulting in a peak bandwidth of up to 1 GB per second. The Matrox System Interface Bridge (SIB), a four-port PCI-X® router custom designed by Matrox Imaging, handles the PCI-X® connections on the Matrox Odyssey Xpro.

The Matrox Odyssey Xpro includes a pair of link ports dedicated to interconnecting multiple boards. The link ports provide point-to-point PCI-X® connections delivering up to 1 GB per second of bandwidth. They off-load the host PC bus by carrying video and message streams (see Matrox Oasis ASIC section) between boards. Video and message streams can be broadcasted or routed to specific processing nodes. A Matrox Odyssey Xpro configuration with multiple boards can be programmed to implement a variety of processing topologies, such as parallel, round robin and pipeline. Parallel topology consists of each processing node operating on a different part of a single image. Round robin topology consists of each processing node operating on a successive image. Pipeline topology consists of each processing node performing a distinct operation on a single image. These topologies can be combined and apply to applications with a single or multiple video sources. In all cases, the processing capabilities of a multi-board system scale-up in a complete linear fashion as each additional node includes a dedicated bank of memory. This flexibility enables the Matrox Odyssey Xpro to handle any application requirements today and in the future.

»» Dedicated board-to-board interconnects

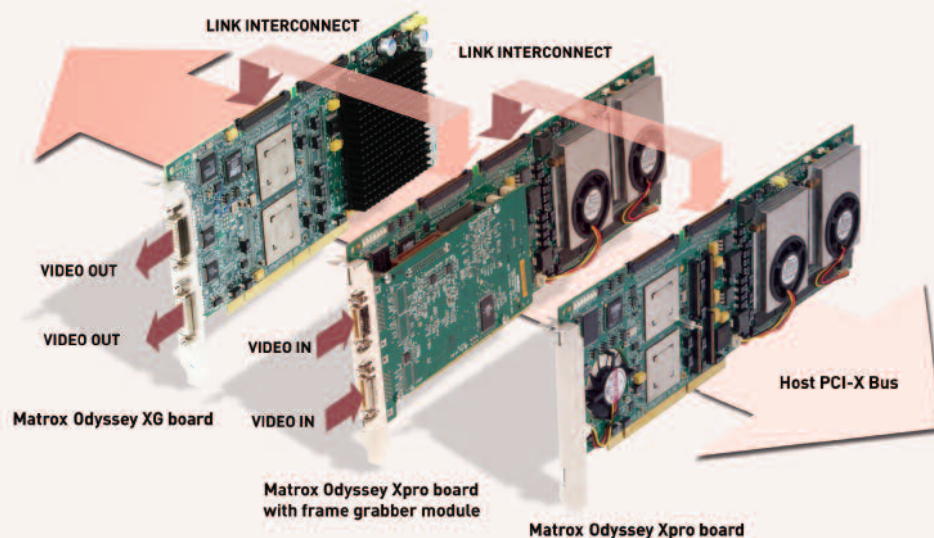

Flash EEPROM for full autonomy

Matrox Odyssey Xpro has a flash EEPROM that stores the G4 PowerPC™ boot sequence, system initialization parameters and a debugging utility. It can also be used to store the operating system and application program in order to implement a truly autonomous system from power-up.

Frame grabbers to match

A standard PCI mezzanine card (PMC) site located on the Matrox Odyssey Xpro board allows the addition of a Camera Link®, analog or LVDS/RS-422 frame grabber module⁵. These frame grabber modules enable the Matrox Odyssey Xpro to capture from the majority of area or line scan video sources.

Camera Link® frame grabber module

The Camera Link® frame grabber module is available in one of two factory-configured versions. The dual-Base version enables simultaneous acquisition from two completely independent Camera Link® video sources utilizing the Base configuration⁶. The single-Full configuration acquires from a single Camera Link® video source utilizing the Base, Medium or Full configuration⁶. Both versions can operate at full Camera Link® speed and include an internal video generator for troubleshooting installation and operation.

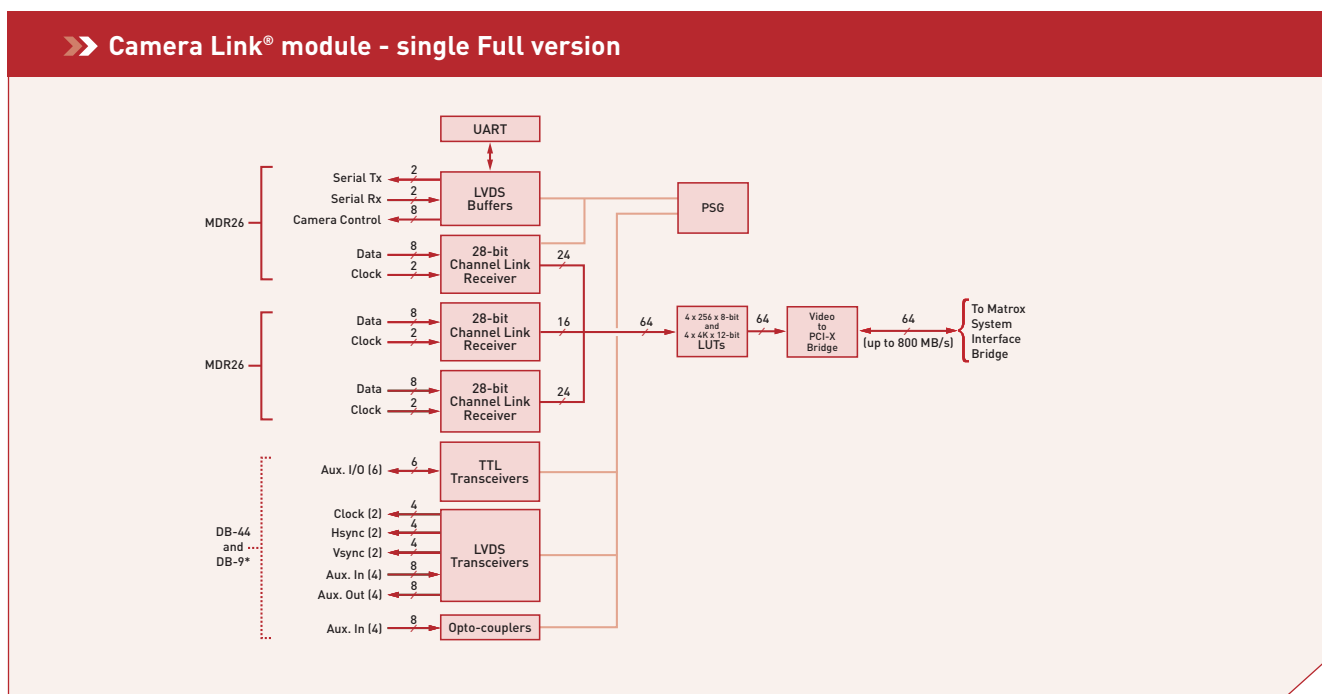
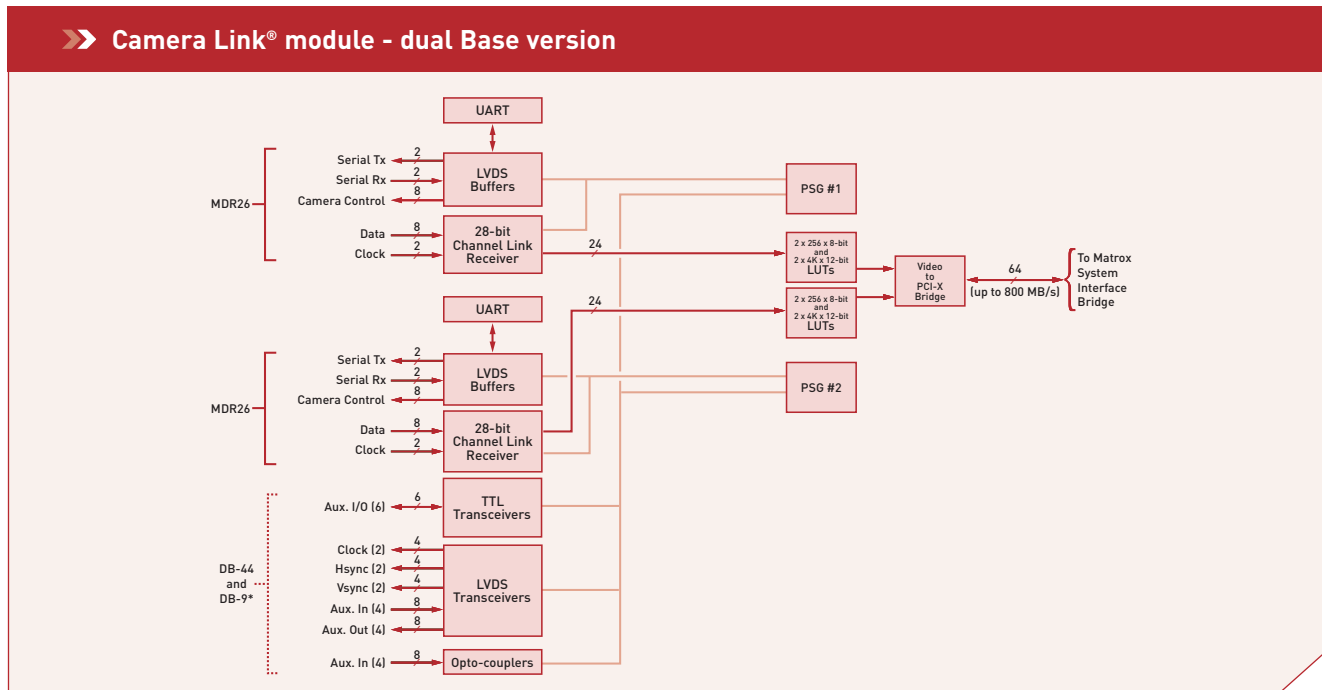

Analog frame grabber module

The analog frame grabber module has four completely independent inputs, each capable of high frequency and high fidelity video capture. In addition to being able to simultaneously acquire from four single-tap video sources, the inputs can be combined to simultaneously acquire from two dual-tap video sources or one RGB and one single-tap video source.

The inputs can also be combined to simultaneously acquire from two video sources at double the nominal acquisition rate. The analog frame grabber module also includes an internal video generator for troubleshooting installation and operation.

LVDS/RS-422 frame grabber module

Designed to support legacy scientific, industrial and medical imaging devices, the LVDS/RS-422 frame grabber module features four completely independent 16-bit wide inputs. These inputs can be configured to acquire from two, four and eight-tap monochrome sources as well as RGB sources. The LVDS/RS-422 frame grabber module also includes an internal video generator for troubleshooting installation and operation.

Adding frame grabber modules

An additional frame grabber module can be added to a Matrox Odyssey Xpro board by way of the Matrox Odyssey PMC carrier board. The Matrox Odyssey PMC carrier board occupies an additional PCI/PCI-X® slot and features a PMC site, which hosts a frame grabber module. The frame grabber module interacts with a Matrox Odyssey Xpro board over the link ports provided on the Matrox Odyssey PMC carrier board (see Lightning fast connectivity section).

» Matrox Odyssey PMC carrier board

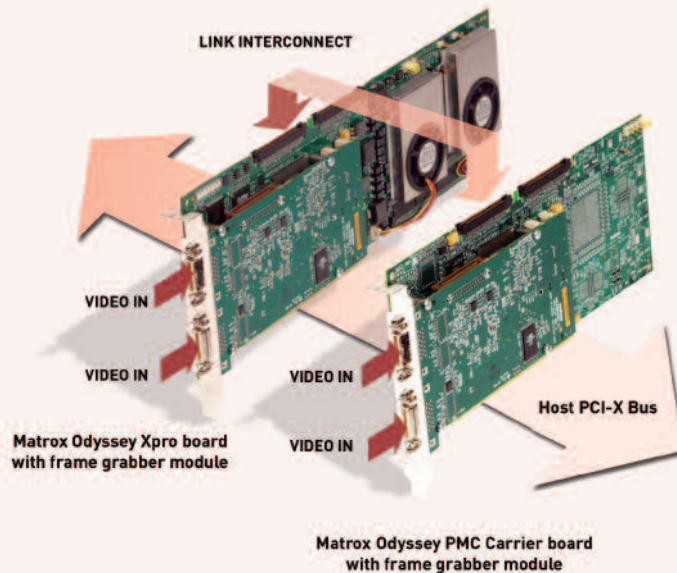

» Analog module

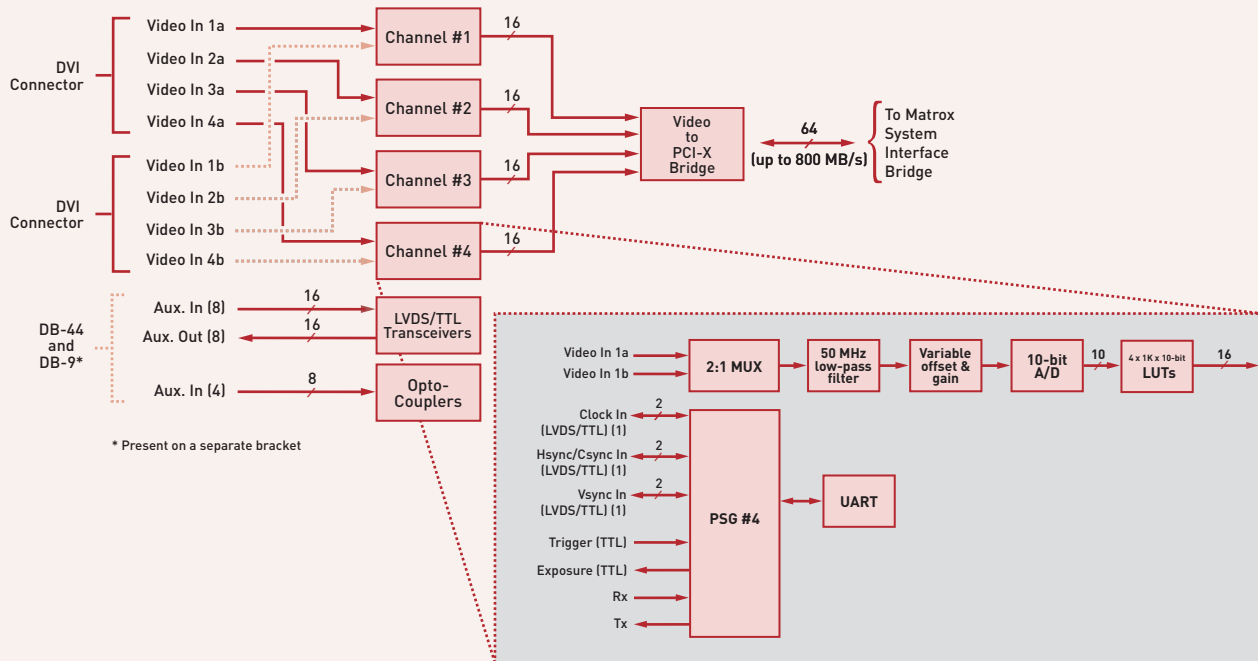

» LVDS/RS-422 digital module

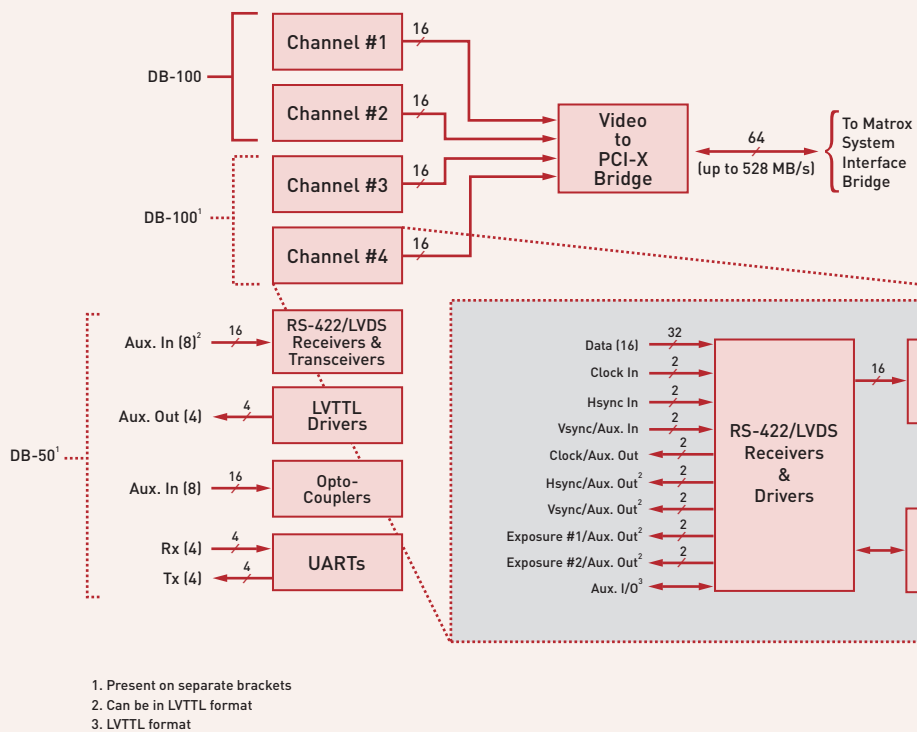

All-encompassing programming environment

The Matrox Odyssey Xpro offers the developer a choice of application programming interfaces (APIs) and programming models. Application developers can program the board using the Matrox Imaging Library or Matrox Odyssey Native Library, each with royalty-free run-time environments². The application program can run on the host PC to remotely control the Matrox Odyssey Xpro (i.e., options A and B) or it can be made to run entirely on the Matrox Odyssey Xpro (i.e., options C and D).

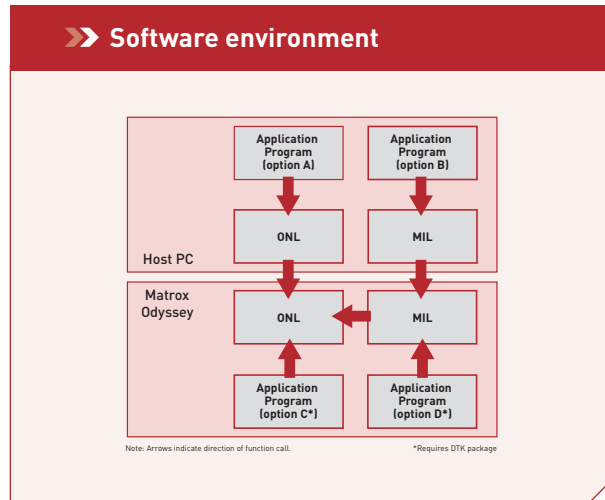

Matrox Imaging Library (MIL)

MIL is a complete and easy-to-use programming library for image capture, processing, analysis, display and archiving that supports the complete line of existing and future Matrox Imaging hardware. MIL's field-proven processing and analysis functions include point-to-point, statistics, filtering, morphology, geometric transformations, FFT, segmentation, pattern recognition, blob analysis, edge extraction and analysis, measurement, character recognition, 1D and 2D code reading, calibration, and JPEG/JPEG2000 image compression. These functions run on the Matrox Odyssey Xpro and are fully optimized for the G4 PowerPC™ and PA.

MIL for the Matrox Odyssey Xpro is carefully tuned to exhibit low function call overheads, maximizing application efficiency and performance. A MIL-based application program can run efficiently on a single processing node or across multiple processing nodes. MIL provides transparent image display management with automatic tracking and updating of image display windows at live video rates. MIL also allows for image display in a user-specified window. In addition, MIL supports live display of multiple video streams using multiple independent windows or a single mosaic window. Moreover, MIL provides non-destructive graphics overlay, suppression of tearing artifacts and filling the display area at live video rates. All of these features are performed with little or no host CPU intervention when using the appropriate graphics hardware. Refer to the MIL datasheet for more information.

Odyssey Native Library (ONL)

ONL is an easy-to-use programming library specific to the Matrox Odyssey family of vision processor boards. The programming interface is compatible with the Matrox Genesis family of vision processor boards. Aside from video capture and system control including multiple processing nodes, ONL includes functions for image processing, normalized grayscale correlation-based pattern recognition, blob analysis and JPEG compression. These functions are fully optimized to exploit the power of the G4 PowerPC™ and PA. ONL functions exhibit the lowest call overheads.

Programming models

Application programs for the Matrox Odyssey Xpro can run in a host-driven or fully embedded mode. In the host-driven mode, the application program runs on the CPU of the host PC and remotely sends commands to the Matrox Odyssey Xpro for execution. The host-driven mode is the easiest to implement but it may be subject to the lack of determinism of the host PC platform. In the fully embedded mode, the application program runs directly on the G4 PowerPC™. The application program has little or no interaction with the host PC platform, ensuring deterministic behavior. Using the fully embedded mode requires the Matrox Odyssey Developer's Toolkit.

Matrox Odyssey Developer's Toolkit

The Matrox Odyssey Developer's Toolkit (DTK) allows a developer to extract the full power of the Matrox Odyssey Xpro. In addition to giving the means to run a MIL and/or ONL-based application program directly on the G4 PowerPC™, the Matrox Odyssey DTK lets a developer further optimize an algorithm by merging ONL functions to reduce main memory I/O bottlenecks.

The Matrox Odyssey DTK also allows developers to write custom G4 PowerPC™ and PA functions. Custom G4 PowerPC™ code is written entirely in C/C++ including optimizations for AltiVec™ technology. AltiVec™ technology is programmed through C language extensions and intrinsic functions. No exotic assembly code is required. Custom PA code is done through a low-level API and pseudo-assembly language. Refer to the Matrox Odyssey Developer's Toolkit datasheet for more information.

Utilities

Bundled with the MIL and ONL software development kit is the Matrox Intellicam camera configuration utility. Matrox Intellicam is a Windows®-based program that lets users interactively configure the frame grabber modules to capture from a variety of video sources. Also included is an interactive system configuration and debugging utility that incorporates a multi-board configuration tool, memory and command viewer, performance monitor and system diagnostic tool.

Operating system support

Supported host environments for the Matrox Odyssey Xpro are Microsoft® Windows® 2000, Windows® XP and Linux³. The G4 PowerPC runs an off-the-shelf RTOS with a very small footprint and fast response to task switches and interrupts.



Vision processors

Matrox **Odyssey XG** >>>

High-fidelity video and graphics display.



Key features

- > PCI-X® card
- > 256-bit GPU
- > 128 MB DDR SDRAM
- > pair of dedicated board-to-board interconnects
- > digital and analog (including TV) output capabilities
- > 10-bit 400MHz RAMDACs
- > support for multi-display configurations (two VGA or single VGA plus TV)
- > display drivers for Microsoft® Windows® 2000 and Windows® XP

Leading edge display for PCI-X®

The Matrox Odyssey XG is a PCI-X® graphics board designed to deliver leading edge display functionality and quality to a Matrox Odyssey Xpro+ video capture and processing system. A Matrox-designed 256-bit GPU gives the Matrox Odyssey XG the ability to deliver ultra-sharp high-resolution graphics and video, and drive up to two analog or digital monitors or a single monitor and a standard definition TV output.

The Matrox Odyssey XG is equipped with a pair of link ports making it an ideal companion to the Matrox Odyssey Xpro+. The dedicated point-to-point PCI-X® connections provided by the link ports enable image transfers from a Matrox Odyssey Xpro+ cluster to a Matrox Odyssey XG without consuming the host PC's precious PCI/PCI-X® bus bandwidth.

>>> Display configurations, formats and max. resolutions

		DVI-I connector #1		DVI-I connector #2	
		Output format	Max. resolution	Output format	Max. resolution
Single head	DVI		1600x1200@60Hz	N/A	N/A
	Analog RGB		2048x1536@85Hz	N/A	N/A
Dual head	Analog RGB	1920x1440@60Hz		Analog RGB	1600x1200@60Hz
	Analog RGB	1920x1440@60Hz		TV ¹	NTSC/PAL
	Analog RGB	1920x1440@60Hz		DVI	1600x1200@60Hz
	DVI	1600x1200@60Hz		DVI	1600x1200@60Hz
	DVI	1600x1200@60Hz		Analog RGB	1600x1200@60Hz
	DVI	1600x1200@60Hz		TV ¹	NTSC/PAL

1. Requires DVI-I to DVI-BNC adaptor cable.
 2. Through 8-bit RAMDACs.

» Matrox Odyssey XG

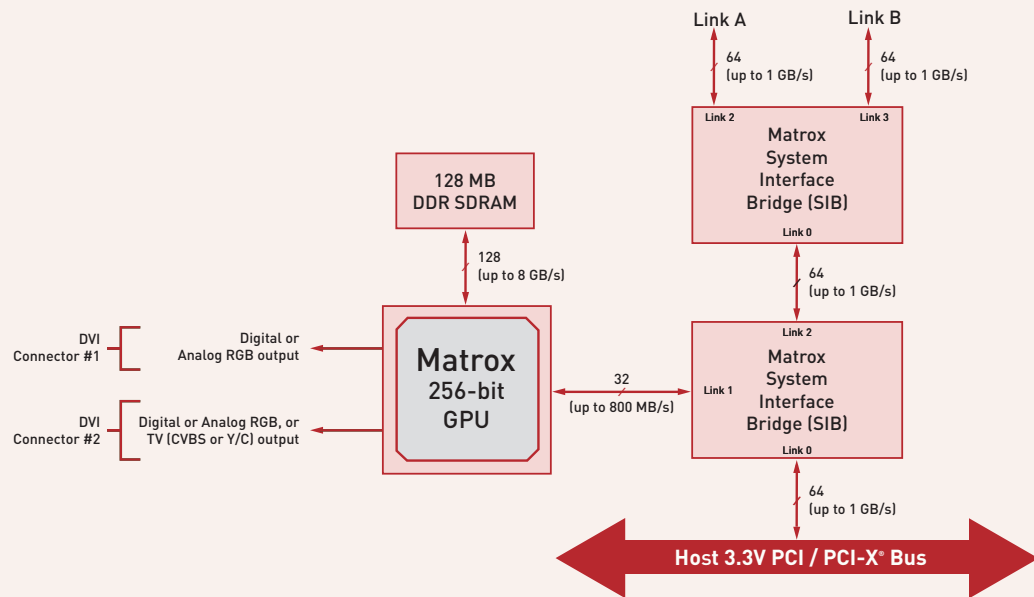

Specifications

Hardware

- PCI/PCI-X® card with 3.3V 64-bit card edge connector
- Matrox-designed 256-bit GPU
- 128 MB DDR SDRAM
- two 64-bit 33/66 MHz 3.3V PCI and 64-bit 66/100/133 MHz PCI-X® dedicated links
- 64-bit 33/66 MHz 3.3V PCI and 64-bit 66/100/133 MHz PCI-X® host interface

Dimensions and environmental information

- 24.8 L x 10.7 H x 1.9 W cm (9.8" x 4.2" x 0.75") from bottom edge of goldfinger to top edge of board, and without bracket and retainer
- power consumption (typical): 2.75A @ 3.3V or 9.1W, 0.8A @ 5V or 4.0W, 0.3A @ 12V or 3.6W, or 16.7W total
- operating temperature: 0° C to 55° C (32° F to 131° F)
- ventilation requirements: 100 LFM (linear feet per minute) over board
- relative humidity: up to 95% (non-condensing)
- FCC class A
- CE class A
- RoHS-compliant

Software

- display drivers for Microsoft® Windows® 2000 and Windows® XP

Ordering Information

Boards

Part number	Description
OG 12M L0 DDVI 0*	PCI-X® graphics board with 128 MB DDR SDRAM and link port interconnects. Includes two DVI-I to HD-15 adaptors.

Software

Display drivers included in the Matrox Odyssey SDK and DTK.

Cables

Part number	Description
DVI-T0-DVIBNCSV	DVI-I to DVI-I, two BNC and two SVHS adaptor (required for TV output).

DVI and HD-15 cables available from third parties.

Specifications

Processor board

- PCI/PCI-X® long card with 3.3V 64-bit card edge connector
- 1.3 GHz MPC7457 (167 MHz MPX bus)
- 2 MB of DDR SRAM L3 cache
- 512 MB, 1 GB or 2 GB of 167 MHz DDR SDRAM main memory
- 16 MB flash EEPROM
- 64-bit 33/66/100/133 MHz 3.3V PMC site
- two 64-bit 33/66 MHz 3.3V PCI and 64-bit 66/100/133 MHz PCI-X® dedicated links
- 64-bit 33/66 MHz 3.3V PCI and 64-bit 66/100/133 MHz PCI-X® host interface

Camera Link® frame grabber module⁵

- two factory configured versions
 - two independent Camera Link® Base ports⁶ (dual-Base)
 - single Camera Link® Base/Medium/Full port⁶ (single-Full)
- Channel Link™ speed of up to 85 MHz
- supports frame and line-scan video sources
- four 256 x 8-bit and four 4K x 12-bit LUTs
- six TTL configurable auxiliary I/Os
- four LVDS configurable auxiliary inputs
- four LVDS configurable auxiliary outputs
- two separate LVDS pixel clock, hsync and vsync outputs
- four opto-isolated configurable auxiliary inputs
- internal video generator for diagnostics

Analog frame grabber module⁵

- four independent video inputs with
 - 2:1 mux
 - AC or DC coupling
 - 50 MHz low pass filter with bypass
 - variable gain amplifier and adjustable references
 - 10-bit A/D with sampling rate up to 100 MHz
 - SNR of 50.4 dB⁷
 - pixel jitter of ± 4.3 ns⁸
 - adjustable clock phase (256 steps with 0.5 ns resolution)
 - four 1K x 10-bit LUTs
 - LVDS/TTL pixel clock, hsync/csync, and vsync inputs or outputs
 - TTL trigger input and exposure output
 - serial communication port
- inputs can be combined to acquire from
 - component RGB video source
 - two dual-tap monochrome video sources
 - two monochrome video sources at up to 200 MHz
- supports frame and line-scan video sources
- eight TTL/LVDS configurable auxiliary inputs
- eight TTL/LVDS configurable auxiliary outputs
- four opto-isolated auxiliary inputs
- PROM for storing calibration parameters
- internal video generator for diagnostics

LVDS/RS-422 frame grabber module⁵

- four independent video inputs with
 - 16-bit wide LVDS or RS-422 interface
 - acquisition rates up to 60 MHz for LVDS and 32 MHz for RS-422
 - 256 x 8-bit and 4K x 12-bit LUTs
 - LVDS/RS-422 clock, hsync and vsync/auxiliary inputs
 - five LVDS/RS-422 configurable auxiliary outputs (four can be LVTTTL)
 - three LVTTTL configurable auxiliary I/Os
 - serial communication port

- can be configured to acquire from
 - four single-tap 8 to 16-bit or dual-tap 8-bit monochrome sources
 - two dual-tap 10 to 16-bit or four-tap 8-bit monochrome sources
 - single four-tap 10 to 16-bit or eight-tap 8-bit monochrome source
 - two 8-bit RGB sources
 - single 10 to 16-bit RGB source
- supports frame and line-scan video sources
- eight LVDS/RS-422 configurable auxiliary inputs (two can be LVTTTL)
- four LVDS/RS-422 configurable auxiliary outputs
- eight opto-isolated configurable auxiliary inputs
- internal video generator for diagnostics

PMC carrier board

- PCI/PCI-X® card with universal 64-bit card edge connector (only draws power)
- 64-bit 33/66/100/133 MHz 3.3V PMC site
- two 64-bit 33/66/ MHz 3.3V PCI and 64-bit 66/100/133 MHz PCI-X dedicated links

Dimensions and environmental information

- 31.2 L x 10.7 H x 1.73 W cm (12.3" x 4.2" x 0.68") from bottom edge of goldfinger to top edge of board, and without bracket and retainer⁷
- power consumption (typical)
 - 6.01A @ 3.3V or 19.83W, 5.89A @ 5V or 29.45W, or 49.28W total for processor board
 - 1.04A @ 3.3V or 3.4W, 0.15A @ 5V or 0.8W, or 4.2W total for PMC carrier board
 - 1.21A @ 3.3V or 4W, 0.92A @ 5V or 4.6W, 0.33A @ 12V or 4W, or 12.6W total for analog frame grabber module
 - 0.75A @ 3.3V or 2.5W, 0.3A @ 5V or 1.5W, or 4W total for Camera Link® frame grabber module
 - 0.97A @ 3.3V or 3.2W, 0.24A @ 5V or 1.2W, or 4.4W total for LVDS/RS-422 frame grabber module
- operating temperature: 0° C to 55° C (32° F to 131° F)
- ventilation requirements: 150 LFM (linear feet per minute) over board(s)
- relative humidity: up to 95% (non-condensing)
- FCC class A
- CE class A
- RoHS-compliant

Software Environment

- host driver for Microsoft® Windows® 2000, Windows® XP and Linux³
- application (control) program running under Windows® on host PC developed using
 - MIL/ONL ('C' DLLs) with Microsoft® Visual C++®.NET 2003
 - ActiveMIL (ActiveX controls) with Microsoft® Visual Basic®.NET 2003 or Visual C++®.NET 2003
- application (control) program running under Linux³ on host PC developed using ONL with GNU Compiler Collection (GCC)³
- application program running on board developed using Matrox Odyssey DTK (MIL and/or ONL) with Metrowerks® CodeWarrior® for PowerPC Embedded Systems

Ordering Information

Boards

Part number	Description
OP4 13G 5M xxxx*	Scalable PCI-X [®] vision processor board with 1.3 GHz MPC745x, 512 MB DDR SDRAM ¹⁰ and optional frame grabber module.
OCB xxxx*	PMC carrier board with optional frame grabber module.
OLPIC*	Link port interconnect board.

NOTE: Remove xxxx for no frame grabber module or replace with suffix below for appropriate frame grabber module. Frame grabber modules are not available separately.

...SFCL...	Single-FULL Camera Link [®] frame grabber module and cable adapter board.
...DBCL...	Dual BASE Camera Link [®] frame grabber module and cable adapter board.
...QHAL...	Quad-input high-frequency analog frame grabber module and cable adapter board (LVDS aux I/O).
...QDL or R...	LVDS/RS-422 frame grabber module and cable adapter boards.

Software

Part number	Description
MIL ONL WIN SDK	Matrox Odyssey Software Development Toolkit (SDK) under Windows [®] . Includes CD with Matrox Imaging Library (MIL) for Odyssey ² , Odyssey Native Library (ONL), Intellicam and online/printed documentation. Note: For creating an application program to control board from host PC.
MIL ONL WIN DTK	Matrox Odyssey Developer's Toolkit (DTK) under Windows [®] . Includes CD with MIL for Odyssey ² , ONL, MIL DTK, ONL DTK, Intellicam and online/printed documentation. Note: For creating an application program running directly on board.
MIL ONL LNX SDK ³	Matrox Odyssey Software Development Toolkit (SDK) under Linux ³ . Includes CD with Matrox Imaging Library (MIL) for Odyssey ² , Odyssey Native Library (ONL) and online/printed documentation. Note: For creating an application program to control board from host PC.

Software Maintenance Program

Included in the original purchase price of the Matrox Odyssey SDK and DTK, it entitles registered users to one year of technical support and free updates.

Part number	Description
MIL ONL MAINT	One year program extension.

Cables

Part number	Description
DVI-TO-8BNC/O	8' or 2.4 m, DVI to 8 BNCs and open end cable for analog frame grabber module (requires customization).
DBHD100-TO-OPEN	3 m (10') high density DB-100 to open end cable for LVDS/RS-422 frame grabber module (requires customization).

Cables

Camera Link[®] cables available from camera manufacturer, 3M Interconnect Solutions (www.3m.com), Intercon1 (www.nortechsys.com/intercon) or other third parties. Cables for cable adapter boards available from third parties.

Notes:

1. Billion operations per second.
2. MIL for Odyssey includes MIL for IA32 (host PC), which requires an additional development or run-time license.
3. Contact local representative or Matrox Imaging Sales for availability.
4. Only one source buffer for MAC unit.
5. Frame grabber modules only work with Matrox Odyssey Xpro.
6. Refer to Camera Link[®] specification for more information.
7. Measured with 50MHz low pass filter.
8. Measured with a horizontal reference signal at 15.7 kHz (RS-170).
9. 24.8L x 10.7H x 1.9W cm (4.8" x 4.2" x 0.75") for PMC carrier board.
10. Also available with 1 GB or 2 GB DDR SDRAM.

Corporate headquarters:

Matrox Electronic Systems Ltd.
1055 St. Regis Blvd.
Dorval, Quebec H9P 2T4
Canada
Tel: +1 (514) 685-2630
Fax: +1 (514) 822-6273

**For more information, please call: 1-800-804-6243 (toll free in North America) or (514) 822-6020
or e-mail: imaging.info@matrox.com or <http://www.matrox.com/imaging>**

matrox

All trademarks by their respective owners are hereby acknowledged. Matrox Electronic Systems, Ltd. reserves the right to make changes in specifications at any time and without notice. The information furnished by Matrox Electronic Systems, Ltd. is believed to be accurate and reliable. However, no responsibility license is granted under any patents or patent rights of Matrox Electronic Systems, Ltd. Windows and Microsoft are trademarks of Microsoft Corporation. MMX and the MMX logo are registered trademarks of Intel Corporation. Printed in Canada, 2007-03-26. **5IE-5281-D**